

NOTES:

1. THIS SHEET IS FOR SCREEN KIT USING STANDARD FIXINGS.
2. ITEMS MARKED 'X' ARE NOT PART OF THE STANDARD KIT BUT ARE OPTIONAL EXTRAS.
3. IF BAFFLE IS NOT TO BE FITTED, USE SAME FIXING DETAIL AS THE OTHER TWO POSITIONS SHOWN.
4. IF ACCESSORY BAR IS NOT FITTED, NONE OF THE FIXINGS ARE INCLUDED EITHER.
5. SCREEN KIT IS OFFERED IN BOTH NATURAL OR BLACK POWDER COATED FINISH.

POS.	QTY.	PART NUMBER	DESCRIPTION
1	1	MOT-STL-001	COWL BRACKET, LH, MOTO GUZZI STELVIO 2008 MY
2	1	MOT-STL-002	COWL BRACKET, RH, MOTO GUZZI STELVIO 2008 MY
3	1	MOT-STL-003	SCREEN BRACKET, LH, MOTO GUZZI STELVIO 2008 MY
4	1	MOT-STL-004	SCREEN BRACKET, RH, MOTO GUZZI STELVIO 2008 MY
5	4	N/A	STELVIO COWL SPACER
6	8	N/A	M6 COUNTERSUNK FINISHING WASHER
7	4	N/A	M6 X 16, SOCKET COUNTERSUNK SCREW
8	4	N/A	STELVIO SCREEN SPACER
9	4	N/A	M6 X 27, SOCKET COUNTERSUNK SCREW
10	6	N/A	M6 FORM G FLAT WASHER
11	8	N/A	M6 LOCKING NUT (NYLOCK)
12	1	UNI-001	ACCESSORY BAR
13	8	N/A	M6 X 18 X2, NYLON WASHER
14	4	N/A	M6 X 25 X 1.6, NYLON WASHER
15	1	MOT-STL-006	BAFFLE, MOTO GUZZI STELVIO 2008 MY
16	2	N/A	M6 X 25, SOCKET CAP HEAD SCREW
17	2	N/A	M6 X 20, SOCKET COUNTERSUNK SCREW
18	4	N/A	M6 X 12 X 0.8, FLAT WASHER
19	2	N/A	M6 X 25, SOCKET COUNTERSUNK SCREW

X

X

		Surface ISO 1302 Vers. 2002	Surface treatment		Preferred material SEE PART DRAWINGS	
Check for product safety necessary (PS)		Size ISO 14405(E)	Technology of production	Mass	Surface area	
Drawn	Date	Name	Description SCREEN KIT ASSEMBLY, MOTO GUZZI STELVIO 2008 MY		Type of supplementary document	
Checked			Project classification		Comp. level	Comp. counter
Techn.					Comp. char.	
PS						
Released						
Laboratory/Office			Change no.	Date	Name	Scale 1:2
Document no. MOT-STL-005			Doc. type	Doc. part	Version 1	Sh. 1 of 2

Refer to protection notice ISO 16016 / Copyright reserved
 Modell Name: MOT-STL-005, ISSUE 1 / Configuration: Standard Fixings / Drawing Name: MOT-STL-005, ISSUE 1

1 2 3 4 5 6 7 8

A
B
C
D
E
F

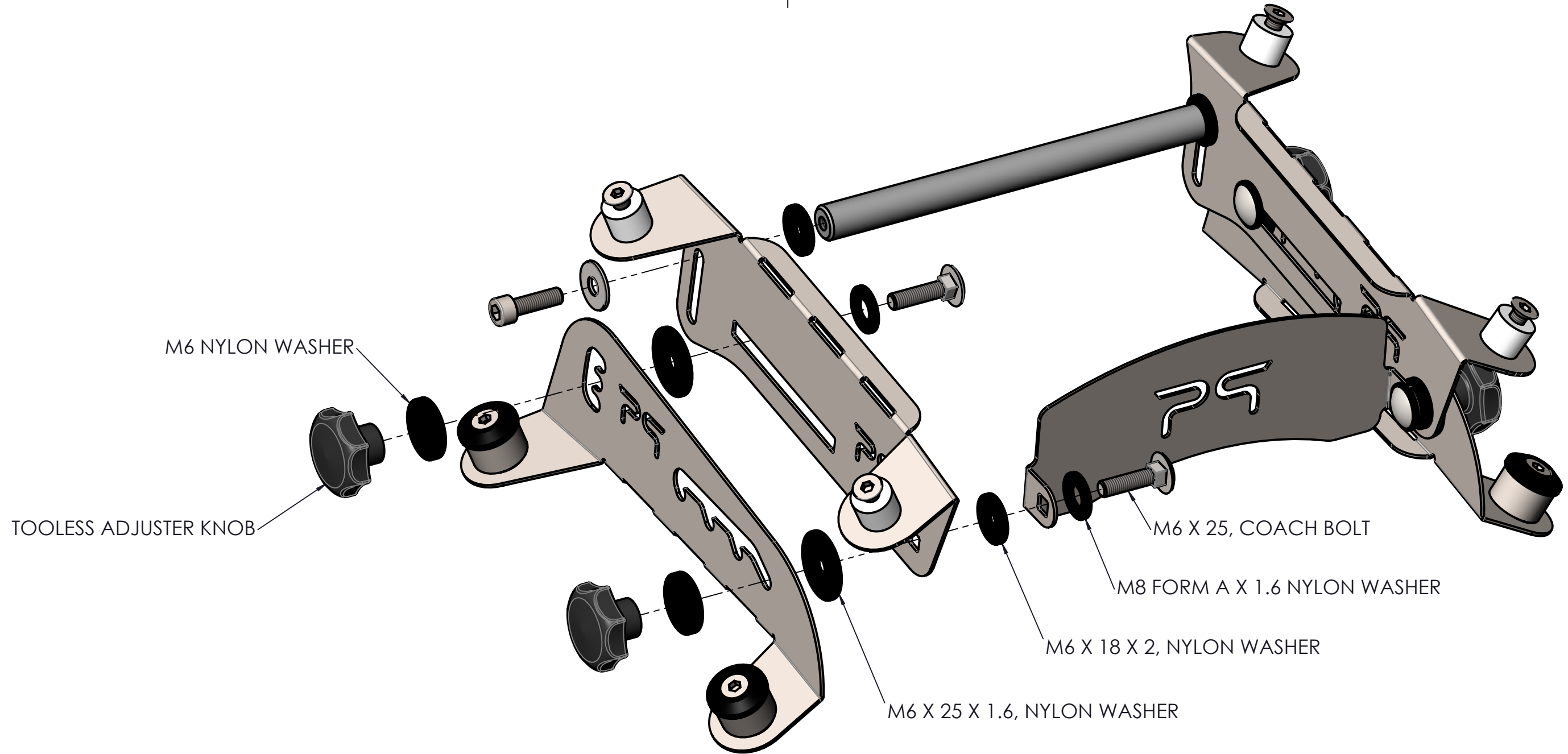

M6 NYLON WASHER

TOOLESS ADJUSTER KNOB

M6 X 25, COACH BOLT

M8 FORM A X 1.6 NYLON WASHER

M6 X 18 X 2, NYLON WASHER

M6 X 25 X 1.6, NYLON WASHER

NOTES:

1. THIS SHEET IS FOR SCREEN KIT FITTED WITH THE OPTIONAL TOOL-LESS ADJUSTERS. EVERYTHING ELSE IS THE SAME AS SHEET 1.

		Preferred material SEE PART DRAWINGS	
		Alternative material	
		Surface ISO 1302 Vers. 2002	Surface treatment
Check for product safety necessary (PS)		Size ISO 14405 (E)	Technology of production
		Mass	Surface area
Drawn	Date	Name	Description SCREEN KIT ASSEMBLY, MOTO GUZZI STELVIO 2008 MY
Checked			Type of supplementary document
Techn.			Project classification
PS			Comp. level
Released			Comp.counter
Laboratory/Office			Comp.char.
		Change no.	Date
		Name	
		Scale 1:1.5	
		Size A3	
		Document no.	Doc. type
		MOT-STL-005	
		Doc. part	Version
		1	
		Sh.	2
		of	2