

****STANDARD FIXINGS****

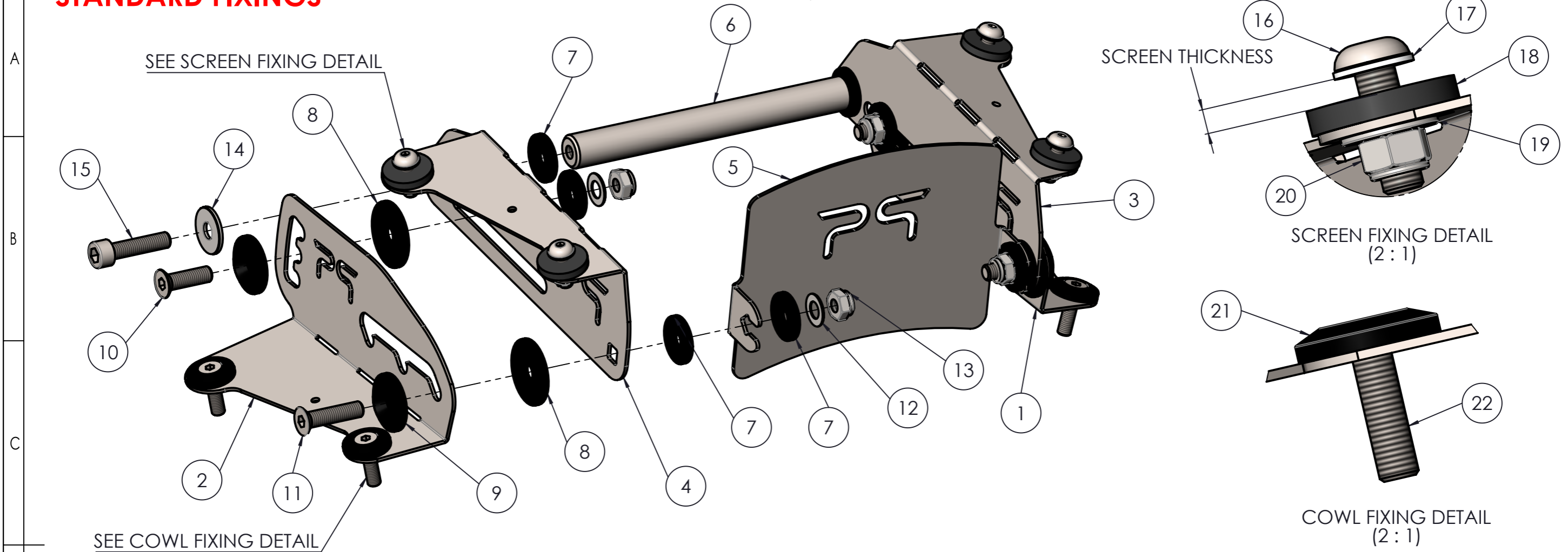

NOTES:

- THIS SHEET IS FOR KITS WITH STANDARD FIXINGS.
- ITEMS MARKED WITH AN 'X' ARE OPTIONAL EXTRAS AND NOT PART OF THE STANDARD KIT.
- KIT IS NATURAL FINISH AS STANDARD BUT BLACK POWDER COATED IS ALSO OFFERED.
- SEE SHEET 2 FOR TOOL-LESS ADJUSTER DETAILS.
- IF HND-C5X-020 (BAFFLE) IS NOT FITTED, USE ITEM 10 INSTEAD OF 11 AND REMOVE 1 OFF ITEM 7.
- IF UNI-001 (ACCESSORY BAR) IS NOT FITTED, THEN ITEMS 7, 14, AND 15 ARE NOT LONGER NEEDED.

X
X

POS.	QTY.	PART NUMBER	DESCRIPTION
1	1	HND-C5X-016	COWL BRACKET, LH, HONDA CB500X 2019 MY
2	1	HND-C5X-017	COWL BRACKET, RH, HONDA CB500X 2019 MY
3	1	HND-C5X-018	SCREEN BRACKET, LH, HONDA CB500X 2019 MY
4	1	HND-C5X-019	SCREEN BRACKET, RH, HONDA CB500X 2019 MY
5	1	HND-C5X-020	BAFFLE, HONDA CB500X 2019 MY
6	1	UNI-001	ACCESSORY BAR
7	8	N/A	M6 X 18 X 2, NYLON WASHER
8	4	N/A	M6 X 25 X 1.6, NYLON WASHER
9	4	N/A	M6 COUNTERSUNK FINISHING WASHER
10	2	N/A	M6 X 20, SOCKET COUNTERSUNK SCREW
11	2	N/A	M6 X 25, SOCKET COUNTERSUNK SCREW
12	4	N/A	M6 X 12 X 0.8, WASHER
13	4	N/A	M6 LOCKING NUT (NYLOCK)
14	2	N/A	M6 FORM G FLAT WASHER
15	2	N/A	M6 X 25, SOCKET CAP HEAD SCREW
16	4	N/A	M5 X 16, SOCKET BUTTON HEAD SCREW
17	4	N/A	M5 FORM B PLASTIC WASHER
18	4	N/A	M4 RUBBER RETAINING WASHER
19	4	N/A	M5 FORM C FLAT WASHER
20	4	N/A	M5 LOCKING NUT (NYLOCK)
21	4	N/A	M5 COUNTERSUNK FINISHING WASHER
22	4	N/A	M5 X 20, SOCKET COUNTERSUNK SCREW

		Surface ISO 1302 Vers. 2002	Surface treatment	Preferred material SEE PART DRAWINGS.
Check for product safety necessary (PS)		Size ISO 14405(E)	Technology of production	Mass
Date Name Description SCREEN KIT ASSEMBLY, HONDA CB500X 2019 MY		Type of supplementary document		
Techn. PS Released Laboratory/Office		Project classification		Comp. level Comp. counter Comp. char.
		Change no.	Date	Name
Document no. HND-C5X-021		Doc. type	Doc. part	Version 1
		Scale 1:1.5		Size A3
		Sh. 1 of 2		

****TOOL-LESS ADJUSTERS****

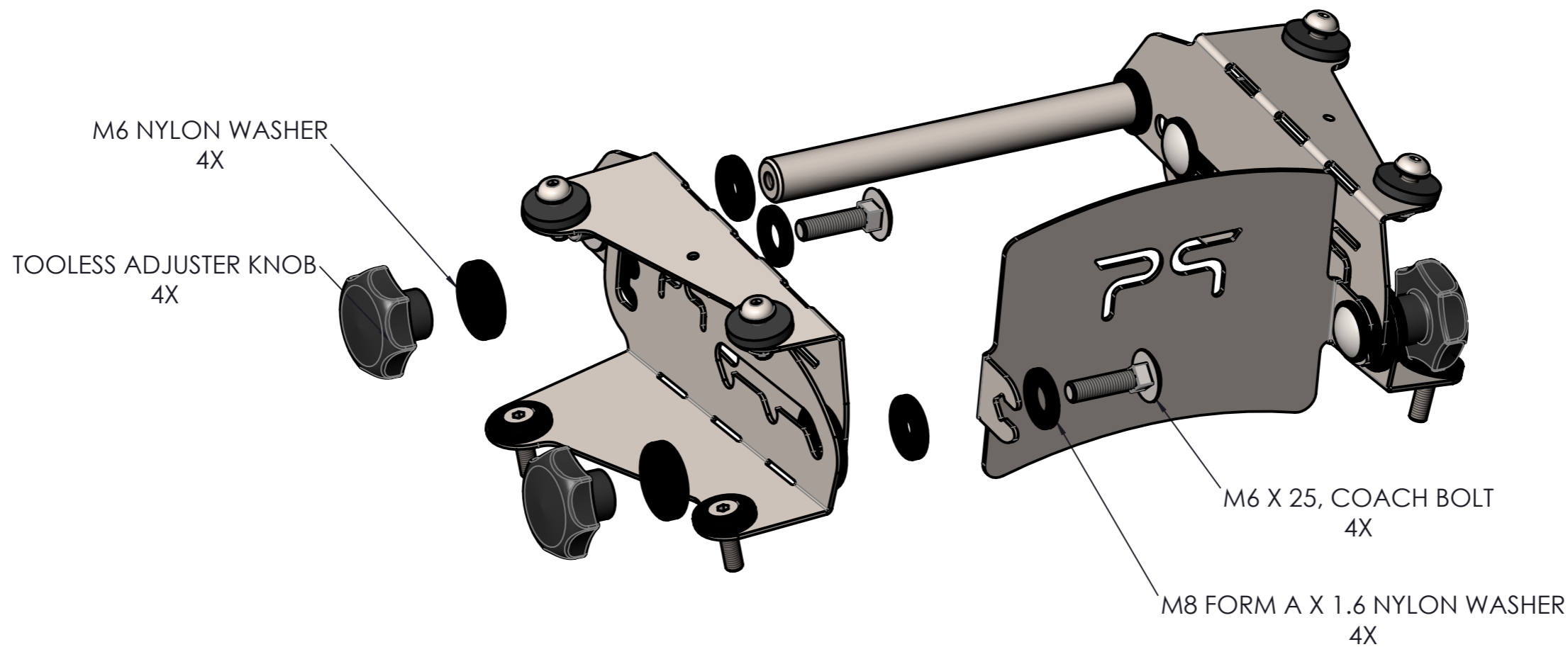

NOTES:

1. THIS SHEET IS FOR KITS WITH OPTIONAL TOOL-LESS ADJUSTER FIXINGS.
2. SEE SHEET 1 FOR STANDARD FIXING DETAILS.
3. ALL OTHER ITEMS ARE THE SAME AS SHEET 1.

		Preferred material SEE PART DRAWINGS.	
		Alternative material	
		Surface ISO 1302 Vers. 2002	Surface treatment
Check for product safety necessary (PS)		Size ISO 14405 (E)	Technology of production
		Mass	Surface area
Drawn	Date	Name	Description
Checked			SCREEN KIT ASSEMBLY, HONDA CB500X 2019 MY
Techn.			Project classification
PS			Comp. level
Released			Comp.counter
			Comp.char.
Laboratory/Office			Scale
	Change no.	Date	Name
	Document no.		Doc. type
	HND-C5X-021		Doc. part
		Version	Sh. 2
		1	of 2